

### » High Mechanical Stiffness

Modern linear guide technology, pre-loaded ball screws and advanced software compensation ensures high displacement precision

### » Wide Speed Range

High precision and improved productivity  
0.01-2032 mm/min (0.0004-80 in/min)

### » Exceptional Load Accuracy

Load accuracy of +/- 0.5% down to 1% of load cell value provides a high dynamic range, thereby reducing the number of load cells required to cover the full force range

### » Large Work Area

180 mm throat depth for larger specimens and wide range of work tables for flexibility

### » Flexible Controls

Scalable from stand alone operation using a control console or utilising our highly acclaimed NEXYGEN*Plus* software

### » Control Interface

PC interface is via USB allowing standard laptops to be used with no special PC interface cards required

### » Advanced Test Setup with NEXYGEN*Plus*

The Windows<sup>®</sup> compatible NEXYGEN*Plus* software features an improved and intuitive User Configurable Test functionality complementing the comprehensive test standards library available



The LS1 is a 1 kN / 225 lbf high precision material testing machine that combined with our extensive range of grips, fixtures, extensometers and software creates a powerful material testing system. The system is equally suited to quality control, educational and R&D environments within a wide range of applications and test types, including medical devices, plastics, packaging, textiles, rubber and electronics to name a few.

- Meets or exceeds national and international material test standards
- Intuitive operation and low maintenance
- Small tabletop footprint with a large and flexible work space
- Plug 'n' Play, automatic identification of YLC series load cells
- NEXYGEN*Plus* provides seamless data transfer to Microsoft Office<sup>®</sup>, LIMS and other data management systems

### Test Types

Tensile Testing • Compression Testing • Flexural Testing • Friction • Insertion/Extraction • Peeling • Tearing • Creep/Relaxation

# NEXYGEN™ PLUS

NEXYGEN*Plus* material testing software is the hub of the Lloyd Instruments material testing system. This extraordinarily easy to use and flexible software, allows the operator to control and monitor all aspects of the system from a single front end, ensuring fast, reliable and powerful testing and data analysis for tensile, compression, peel, creep, relaxation and flexural test applications.

- Large built-in library of test methods meeting international test standards
- Intuitive User Configurable Test facility
- Video and still capture for visual analysis
- Built in SPC functionality for continuous monitoring of process parameters such as Cp and Cpk
- Microsoft Office® integration for seamless transfer of data
- Versatile data export facility to LIMS, SPC or data management systems
- Test automation and batch testing

## Multi-lingual

NEXYGEN*Plus* software is available in the following languages: English • Spanish • French • German • Italian • Danish • Turkish • Chinese • Russian • Polish

## Test Creation

Getting started with NEXYGEN*Plus* is simple, thanks to:

- An extensive built-in library of test methods covering ASTM, DIN, EN, ISO and other standards
- Test wizards for tension, compression, tearing, peeling, friction and flexural tests
- The User Configurable Test facility, ideal for product and component testing, R&D use and specialised testing

## New User Configurable Test

The new User Configurable Test enables users to quickly build advanced multi-stage test routines using simple built-in commands.

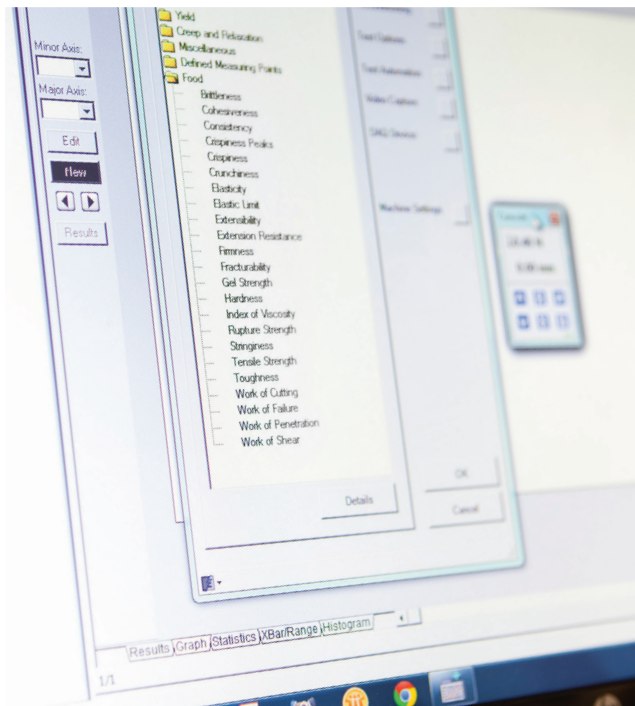

## Video and Still Picture Capture

Whether for advanced sample failure analysis or presentation of test results, video and stills capture is available. Video and/or still pictures can be replayed or shown at specific points during the test in the graphical display. To utilise these powerful features simply connect your web cam or analogue video camera to your PC.

## Test Automation and Customisation

To facilitate the increasing use of automation in manufacturing, NEXYGEN*Plus* has been developed with powerful utilities for systems integration. Typical integration projects include:

- Automated sample handling
- In-line testing
- Monitoring of parameters from other sensors, e.g. thermocouples and strain gauges
- Customisation of the user interface and other functionality via the integrated Microsoft VBA module

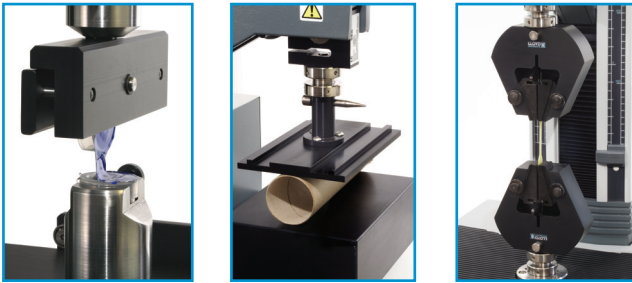

## Flexible and Safe work area

The machine can be equipped with an expanded work table, a T-slot table or a drip tray. For safety splinter shields with electrical interlocks are available in three different heights.

## Grips and Fixtures

Choose from a wide range of standard grips and fixtures as well as custom designed versions.

- Wedge action grips for rigid samples
- Pneumatic action grips for faster sample clamping
- Vice action grips for film and semi rigid materials
- Compression platens available in many sizes
- 3 and 4 point bending jigs
- Self tightening grips to reduce operator fatigue
- Bollard grips for wire and rope testing

## Extensometers

Lloyd has a complete range of contact and non-contact extensometers available.

- General Purpose Contacting Extensometers
- Non-Contacting Extensometer
- High Resolution Strain Gauge Extensometer
- High Resolution Non-Contacting Video Extensometer

The LS1 accepts up to 3 external inputs using an external interface. As standard the LS1 accepts one extensometer input using a cable loom.

## Load Cells

The machine uses Plug'n'Play YLC Series load cells. The load cells feature anti-rotation collars to avoid load train twist and facilitating easy axial alignment. 8 interchangeable YLC load cells are available with different load ratings and resolution.

## Large Sample Testing

The LS1 is fully compatible with the unique pogo system from Lloyd Instruments, here shown with a dual column machine. The pogo system allows testing of very large samples up to 2 x 2 m (78.7 x 78.7 in) in size with the added benefit of optional elevated and low temperature testing capability.

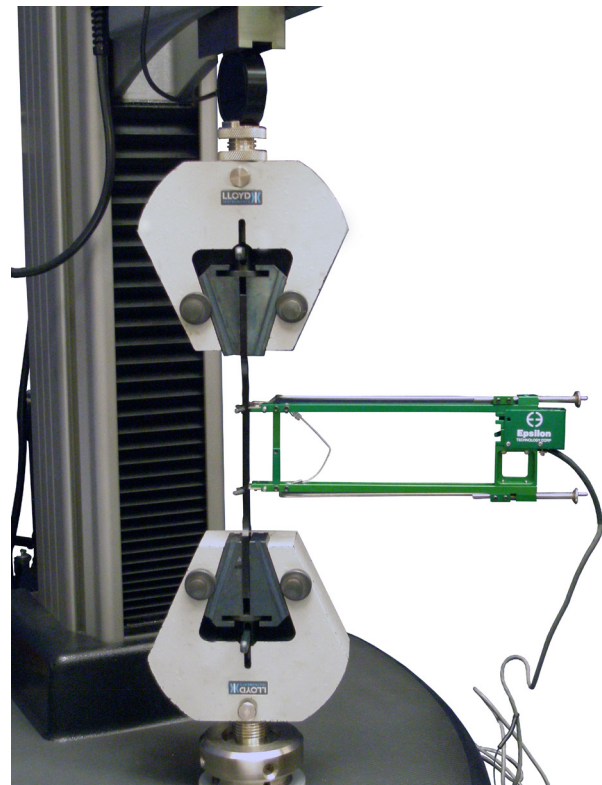

## Technical Specification

Force Capacity	1000 N (225 lbf)
Max. Crosshead Travel, Standard Travel (Between the Eye Ends)	500 mm (19.7 in)
Max. Crosshead Travel, Extended Travel (Between the Eye Ends)	800 mm (31.5 in)
Crosshead Speed Range	0.01-2032 mm/min (0.0004-80 in/min)
Max. Return Speed	2032 mm/min (80 in/min)
Speed Accuracy (Unloaded)	+/-0.2% of selected speed from 2% to 100% of max. speed
Min. Load Resolution (Load Cell Specific)	0.0001N (2.2x10 <sup>-5</sup> lbf)
Load Cell Accuracy	+/-0.5% from 1% to 100% of load cell value
Extension Resolution	<0.15 microns
Data Sampling Rate	8kHz
Load Measuring System	EN ISO 7500:2004, Class 0.5 ASTM E4
Relative Humidity	20% to 85%
Operating Temperature	+5 to 35°C (41 to 95°F)
Storage Temperature	-17 to 54°C (0 to 130°F)
Supply Voltage (+/- 10%)	115VAC/230VAC, 50-60Hz
Max. Power Requirement	150VA

All systems conform to relevant EU standards and are CE marked. On site verification as per ASTM E4 and ISO 7500-1 recommended.

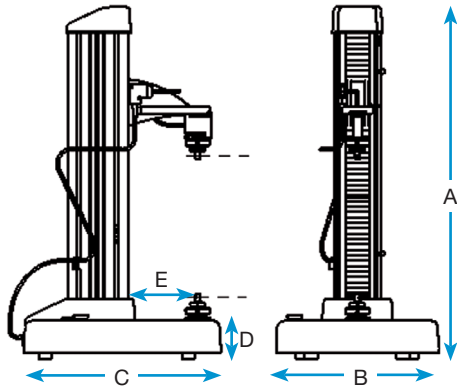

A	Height (standard travel)	1001 mm (39.4 in)
A	Height (extended travel)	1301 mm (51.2 in)
B	Width (excluding console)	460 mm (18.1 in)
C	Depth	557 mm (21.9 in)
D	Base Height	108 mm (4.3 in)
E	Throat Depth	180 mm (7.1 in)
	Weight (standard travel)	52 kg (115 lb)
	Weight (extended travel)	62 kg (137 lb)

## Ordering Information

Order number	Description
LS1	LS1
	<b>Model</b>
S	Standard Travel
E	Extended Travel
P	Standard Travel POGO Design*
X	Extended Travel POGO Design*
	<b>Operation</b>
H	Hand Held Remote
C	Main Console
	<b>Power</b>
	115V US Power Cord
	230V UK and Euro Power Cord
	230V - CNAU China and Australian Power Cord
	<b>Order number sample</b>
LS1 E C	230V LS1, Extended Travel, Main Console, UK and Euro Power Cord

\*Our unique POGO system allows testing of very large samples with the added benefit of optional elevated and low temperature testing capability.

**AMETEK Sensors, Test & Calibration**  
A business unit of AMETEK Measurement & Calibration Technologies offering the following industry leading brands for test instrumentation.

**Chatillon Force Measurement**  
Chatillon has been a hallmark in the industry since 1835. The hand held gauges and motorized testers have earned their reputation for quality, reliability and accuracy and they represent the de facto standard for force measurement.

**Lloyd Instruments**  
*Material Testing Solutions*  
Material testing machines and software from Lloyd Instruments guarantee the highest level of performance and capability for production testing, quality control, laboratory testing, research and education to provide expert material testing solutions.

*Texture Analysers*  
The comprehensive program provides the platform to perform rapid, general food testing and detailed texture analysis on a diverse range of foods.

**Newage Testing Instruments**  
Newage offers a comprehensive range of hardness testers, optical systems and software for measurement, data acquisition and analysis.

**AMETEK®**  
TEST & CALIBRATION INSTRUMENTS

**United Kingdom**  
Tel +44 (0)1243 833 370  
stc.uk@ametek.com

**France**  
Tel +33 (0)1 30 68 89 40  
general.lloyd-instruments@ametek.fr

**Germany**  
Tel +49 (0)2159 9136 510  
info.mct-de@ametek.de

**Denmark**  
Tel +45 4816 8000  
ametektci@ametek.com

**USA**  
*Florida*  
Tel +1 (727) 538 6000  
test.sales@ametek.com

*California*  
Tel +1 (800) 444 1850  
test.sales@ametek.com

**India**  
Tel +91 22 6196 8200  
vivek.bandekar@ametek.com

**Singapore**  
Tel +65 6484 2388  
erik.dwiputra@ametek.com.sg

**China**  
*Shanghai*  
Tel +86 21 5868 5111  
stc.china@ametek.com

*Beijing*  
Tel +86 10 8526 2111  
stc.china@ametek.com

[www.ametektest.com](http://www.ametektest.com)

Information in this document is subject to change without notice. ©2020 by AMETEK, Inc., [www.ametektest.com](http://www.ametektest.com). All rights reserved.